

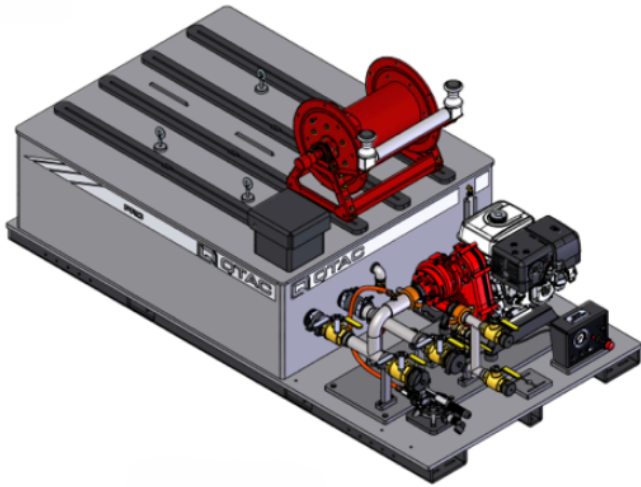

Contact Us



Office : 256.776.7786
Email : sales@firetruckmall.com
Website: www.firetruckmall.com

15410 US Highway 231,
Union Grove, AL 35175
Stock #: 21074
Price: \$18,000

2026 QTAC Tsunami Pro V9 Skid Unit

2026 QTAC Tsunami Pro V9 Skid Unit

Other Chassis

QTAC Tsunami Pro VS2-9EV 400G LONG
BED

○ Waterax VS2-9EV Pump

○ 400 Gallon Polypropylene Tank

○

Engine: Honda GX270 9HP

Pump: WATERAX VS2-9EV

Maximum Pressure: 150 PSI

Maximum Flow: 105 GPM

Hose Reel: Hannay electric reel with 100-ft of 3/4-inch I.D. hose rated to 300 PSI

PUMP & ENGINE

The pump system shall consist of a Honda GX270 four-stroke gasoline engine producing 9

HP coupled to a WATERAX VS2-9EV self-priming centrifugal pump configured for vehicle-

mounted firefighting applications with electric start and battery system.

Pump Performance:

- Maximum Pressure: 150 PSI
- Maximum Flow: 105 GPM
- Maximum Head: 347 feet

Flow & Pressure Ratings:

- 92 GPM @ 50 PSI
- 80 GPM @ 75 PSI
- 64 GPM @ 100 PSI

The pump system shall include:

- One (1) 2-inch NST draft suction
- One (1) 1-1/2 inch NST discharge
- One (1) 1-inch NPSH discharge
- One (1) 1-inch gated pump-to-reel line
- One (1) 1-inch gated pump-to-tank return
- TIG-welded stainless-steel manifold

- Additional equipment not included with purchase unless otherwise listed. Mileage readings may not be real-time and should be confirmed.

- OPTIONAL EQUIPMENT

HOSE

The Tsunami Pro may be configured with one of the following hose packages:

- One (1) Hannay electric hose reel equipped with 200-ft of 3/4-inch I.D. booster hose

rated to 300 PSI

- One (1) Hannay electric hose reel mounted equipped with 100-ft of 1-inch I.D. hose

rated for 300 PSI

FOAM SYSTEM

If the foam option is selected, the Tsunami Pro VS2-9EV shall include:

- One (1) 5 or 10-gallon PolyTough foam tank
- One (1) Scotty 4171 foam proportioner

The Tsunami Pro VS2-9EV skid unit shall have the following overall dimensions:

- Dimensions: Width: 47.625" | Length: 94" | Height (Reel): 59.375"
- Water Weight: 3,340 lbs
- Versax 9: Electric Reel: 681 lbs



Brindlee Mountain Fire Apparatus is one of the world's largest used fire truck sales and service companies. Based just outside of Huntsville, Alabama, the company has forty-five full-time personnel occupying over 12,000 square feet. Our mechanics, all of whom are EVT certified, perform pump tests, general repairs, preventative maintenance, and body, collision, and paint work on over 500 used fire trucks every year. Visit us online at www.firetruckmall.com